

**Hoppers**  
**STOPPERS**



**GIVING CARS THE BRAKE THEY DESERVE**

**HOPPERS STOPPERS**  
**BIG BRAKE KITS**  
**2022/3**

290/300mm Front kits as shown below.  
**330mm and other types see later pages**

## **HOLDEN**

	<u>SMOOTH</u>	<u>SLOTTED</u>	<u>D+SLOTTED</u>		
COMMODORE VR/VS	\$910	\$1030	\$1090	std	Alloy
COMMODORE VB/VP	\$1450	\$1575	\$1635	std	Alloy
HOLDEN HR disc stub axle	\$1815*	\$1940	\$2000	+16mm	
HOLDEN HK/WB	\$1815*	\$1940	\$2000	+8mm	
TORANA LC-LJ/LH-UC disc stub	\$1815*	\$1940	\$2000	+16mm/+2.5mm	
TORANA HB /TA/Viva	\$1815*	\$1940	\$2000		
GEMINI 4 STUD	\$1595*	\$1720	\$1780	+10mm	Alloy
GEMINI 5 STUD	\$1515	\$1635	\$1695	+10mm	Alloy
GEMINI inset (14"- single piston)	\$1570	\$1695	\$1755	<u>-7mm</u>	Alloy
RODEO KB	\$2000*	\$2115	\$2180		
RODEO TF (16")	\$1815*	\$1940	\$2000		
BEDFORD CF VAN - 5 stud only	\$1815	\$1940	\$2000		

- TORANA/HR HUBS IN COMMODORE PATTERN – offset add 5.5MM

**HSV C5-C6 Caliper Bracket Kit**                      **\$300**

## **FORD AUSTRALIA**

65/70 MUSTANG drum stub axle	\$1815	\$1940	\$2000 (Ask if 4 Stud or 5 Stud Car)	
65/70 MUSTANG <u>14" WHEELS</u> (drums Only)	\$1815	\$1940	\$2000 (Reco Calipers-Shelby Wh)	
MUSTANG 67 / 73 disc stubs (XW-XF)	\$1815	\$1940	+8mm	
XK / XP drum stub axle	\$1815	\$1940	\$2000	+6mm
XR / XY drum stub axle	\$1815	\$1940	\$2000	
XW / XF disc stub axle	\$1815	\$1940	\$2000	+8mm
E-SERIES (INC XH)	\$2420	\$2970	\$2970	
CORTINA Mk1/2 CAPRI Mk 1 & 2*	\$1815	\$1940	\$2000	std
CORTINA TC/TD * # NOTE	\$1815	\$1940	\$2000	<u>-6mm</u>
CORTINA TE/TF *	\$1815	\$1940	\$2000	<u>-6mm</u>
ESCORT Mk 1 & 2*	\$1815	\$1940	\$2000	<u>-6mm</u>

**85-95 COURIER 2WD (5 STUD ONLY)** \$1940                      \$1940                      \$2000

**COURIER 355 KIT**                                              \$P.O.A

# CORTINA TC CHANGED BEARINGS 8/72 - ASK BUILD DATE OR BEARINGS NUMBERS

CORTINA Mk1/2 CAPRI Mk1/ 2 – if using 11p type wheel – use DEEP INSET kit

CORTINA TE/TF – 11p type wheel uses CORTINA INSET kit

- **All prices are for 5 stud, add \$80 to kit price for 4 stud**

# FORD USA

	<u>SMOOTH</u>	<u>SLOTTED</u>	<u>D+SLOTTED</u>	
49 / 54 SPINNER king pin stubs	\$1940	\$2050	\$2120	
55 / 58 CUSTOMLINE ball joint stub	\$1940	\$2050	\$2120	(late wheels only)
59 / 68 Fairlane/Galaxie drum stub axle	\$1940	\$2050	\$2120	
66 / 72 Galaxie disc stub axle	\$1940	\$2050	\$2120	
37 to 48 Genuine king pin stubs	\$1940	\$2050	\$2120	
49 to 53 car king pin stubs	\$1940	\$2050	\$2120	
54 to 56 car ball joint stubs/Mercury	\$1940	\$2050	\$2120	
57 to 72 car drum stubs	\$1940	\$2050	\$2120	+6mm
MUSTANG II 300MM	\$1940	\$2050	\$2120	
MUSTANG II 330MM		\$2420	\$2550	
Compact Fairlane drums 287 ( Hq 14")	\$1875	\$2000	\$2060	
Thunderbird 53/60 drum	\$1940	\$2050	\$2120	
Thunderbird 61/64 drum 287 Magna 14"	\$1940	\$2050	\$2120	
Thunderbird 61/64 drum stub axles	\$1940	\$2050	\$2120	
Mercury 49/53 drum kingpin axle	\$1940	\$2050	\$2120	
F100 48 /56 drum kingpin axle *	\$1940	\$2050	\$2120	
F100 57/ 67 drum kingpin axle*	\$1940	\$2050	\$2120	
F100 57/ 67 drum kingpin axle*	\$1940	\$2050	\$2120	
F100 68/72 Single I beam only*	\$1940	\$2050	\$2120	

F100 in Falcon 4.5" pcd      \*add \$250 for: 5x 5.5 pcd 1/2" studs (use S209) F100 pattern and rotor centre to be machined out

# CHEVROLET

(Can Do Booster/Master Kit)

Car 49/54	Corvette 53 to 62	\$2200	\$2330	\$2640		
Full Size	55 - 69	\$2000*	\$2135	\$2200	+28mm	Alloy
" "	Heidts drop stubs	\$2000*	\$2135	\$2200		
Camaro	67/69 drum stubs*	\$2000*	\$2135	\$2200	+9.5mm	
Camaro	67/69 disc stubs*	\$2000	\$2135	\$2200		
Camaro	70 SSBC Drop stub	\$2000	\$2135	\$2200		
Corvette	63/67 drum stubs*	\$2000	\$2135	\$2200		
GT40 & C4	Corvette front - 310x28		\$2265	\$2330		
Corvette	C4 - C6 330mm		\$2530	\$2660		

Smooth rotor kits drilled from blank rotors cost same as slotted.

Chev 55-69 - Hq Brake adaption, Bracket kit      \$550

For A and F body Models see attached lists

(Chev 55-69 C.R.S drop stubs use HQ inset 22mm kit)

(Heidts drop stubs have special kit)

For Camaro, when using master/booster kit, must use Proportional Valve for rear brakes  
Add \$200

	<u>SMOOTH</u>	<u>SLOTTED</u>	<u>D+SLOTTED</u>		
<b><u>CADILLAC</u></b>					
<b><u>Original 5 on 5 pattern (reverse design)</u></b>					
48/56	\$2420	\$2475	\$2540		Alloy
57/60	\$2420	\$2475	\$2540	+20mm	Alloy
61/69	\$2420	\$2475	\$2540		Alloy
<b><u>Chev or Ford/modern wheels only *</u></b>	<b>\$2000</b>	<b>\$2035</b>	<b>\$2180</b>		

- Smooth rotor kits drilled from blank rotors cost same as slotted.

## **Buick**

46-60	\$1940	\$2050	\$2120	55/56 +6mm	57 +24mm
61-64 Riviera	\$1940	\$2050	\$2120	+14.5mm	
65 /70 Riviera	\$1940	\$2050	\$2120		

## **Pontiac**

40/54	\$2120	\$2180	\$2240		
55/58	\$1875	\$2000	\$2060		
59/64	\$1875	\$2000	\$2060		
61/ 64 Bonneville	\$1875	\$2000	\$2060		
65/ 68 Bonneville/ Catalina	\$1875	\$2000	\$2060		
61-68 Laurentian/ Parisienne	See 61-68 Chevrolet				
Pontiac Firebird 67-70 (non chev A body)	\$1940	\$2050	\$2120		

For A and F body models see attached list

## **CHRYSLER Australia and USA**

Valiant VH / CM	\$1815	\$1940	\$2010	std	
S Type to VG –use VH to CM					stub axles
Centura 6 CYL	\$1815	\$1940	\$2010		
Dodge Charger 67/70 etc B Body	\$1815	\$2060	\$2120 (drum)		
Dodge Challenger 69/74 etc E Body	\$1815	\$2060	\$2120 (disc)		
48/ 56 Aussie Plymouth/Dodge etc	\$1815	\$2060	\$2120		
57/61 USA Full size Belvedere etc	\$1815	\$2060	\$2120		
62 / 64 Phoenix/ Dart etc (See Below)	\$1815	\$2060	\$2120		
65 / 68 C body Phoenix /Fury etc	\$1815	\$2060	\$2120		
AT4/D5N/International C1100	\$2660				

NOTE: 62 Phoenix was Model change over, Find Stub Holes measurements  
For B and E body models see attached list

SMOOTH      SLOTTED      D+SLOTTED

## MITSUBISHI

Sigma GH / GN	\$1815	\$1940	\$2010	
L200/L300	\$1815	\$1940	\$2010	REC 16" WHEELS
Magna rear rotors dba 4417		\$240ea	\$300ea	

for 4wd calipers, will require rear rotor spacers, \$140 pair

## JAGUAR (Need modified Cradles)

(Series 1 can change uprights to Series 2-3) NOTE JAG IS CHEV PCD WITH ½ STUDS STANDARD

XJ6 SERIES 2 AND 3.	\$2010	\$2060	\$2120
STD TRACK OR 22mm INSET			

(Note: Different seals Req'd for Series 2 or 3, get Number or Measure) and check bearings on series 2 – A & B to 77 then E & F

XJ40 330mm kit only			
Jag 1952 – Mark 7	\$2120	\$2240	\$2300

## MAZDA

5 stud Kits	\$1815	\$1940	\$2000
4 stud patterns add \$50 per kit			
330mm kits		\$2420	\$2550

RX4 / 929 / 808 / 323 / 929 / 1000 ute / 1300  
 RX2/ Capella / RX3 /RX5 / 626 RWD / 121L  
 RX7 Series 1 Series 2 Series 3

Note some Mazda Models need rear bearing stub collar to work, customer must check old hub parts for collar

R100 USE RX2/3 STRUT

NOTE WHEEL OFFSET 10P OR 38P (29mm outset kit) AVAILABLE SOME TYPES  
 Mazda's are very interchangeable, check bearings etc to confirm struts

B200/2200 – 5 stud only 85-95	\$1815	\$1940	\$2000
-------------------------------	--------	--------	--------

## TOYOTA

	<u>SMOOTH</u>	<u>SLOTTED</u>	<u>D+SLOTTED</u>
Corona XT130, ST141, XT131, RT101, RT118	\$1815	\$1940	\$2010
Celica TA22/RA23/28 RA40 RA65	\$1815	\$1940	\$2010
Supra MA61 / Cressida MX73	\$1815	\$1940	\$2010
Corolla KE10 KE20, KE30, KE55 KE70	\$1815	\$1940	\$2010
Corolla AE86	\$1815	\$1940	\$2010
Crown MS55/MS85	\$1815	\$1940	\$2010
Hilux 2WD only - 1980's to 2003	\$1815	\$1940	\$2010
Hilux 2WD only - 4/07 on 330mm		\$2120	\$2180
Uzz30/31 Soarer 330mm		\$2120	\$2180

## NISSAN

5 stud Kits	\$1815	\$1940	\$2010
4 stud patterns add \$70 per kit			

1000 (Strut Change) 1200 180B 240K STANZA 200B (Aussie assembled)  
BLUEBIRD R30 R31 SKYLINE  
240Z 260Z 280ZX

## 300mm STREET ROD BRAKES

FORD GENUINE 37 TO 48 SPINDLES	\$1940	\$2050	\$2120
ROD TECH REPRO SPINDLES	\$2010	\$2120	\$2180
ROD CITY REPRO SPINDLES	\$2010	\$2120	\$2180

## STUBTECH

03 5472 3864

0447 445 604

## 300mm Kits for Aussie made dropped stubs

HR TO WB drilled for Commodore Calipers	\$1450	\$1575	\$1680	Alloy
Torana drilled for Commodore Calipers	\$1450	\$1575	\$1680	Alloy
HR TO WB drilled for HQ calipers*	\$1815	\$1940	\$2000	
Torana drilled for HQ calipers*	\$1815	\$1940	\$2000	
Chev 55/68 drilled for Commodore calipers	\$1450	\$1575	\$1680	
Chev 55/68 drilled for HQ calipers*	\$1940	\$2060	\$2120	
Valiant (stub axle mods required)	\$1815	\$1940	\$2010	

**\* Smooth rotor kits drilled from blank rotors cost same as slotted.**

Note- kits to suit USA made dropped stubs for Chev sedan, Camaro, Dodge etc made by Heidts, CPP, Fatman, Master Power are available.

# 330 mm KITS.

Note DBA4000 series slotted or Drilled/slotted only

	Slotted	Drilled/slotted	
COMMODORE VB/VY	\$1875	\$1940 AU Sports Calipers	
COMMODORE VB-VP	*NLA*	*NLA* 330 X 32 C5-C6 Calipers (hsv Type)	RED
COMMODORE VT-VY	*NLA*	*NLA* 330 X 32 C5-C6 Calipers (hsv Type)	RED
FORD XW TO XF	\$2420	\$2550	
HQ/WB AND TORANA	\$2420	\$2550	
CHEV 55 / 70	\$2420	\$2550	Alloy
HILUX 2WD 80-2003	\$2420	\$2550	
HILUX 4/03 -	\$2120	\$2240	
Hilux 2005- 2009 2WD only			
330 slotted	\$1875		

Most Kits in our 290 and 300mm range can be supplied in 330 size usually around \$2000/\$2100

## INTERNAL HANDBRAKE REAR BRAKE UPGRADE KIT

*ford pattern only unless 330mm, 330mm kits are double drilled*

### INTERCHANGEABLE SIZES TO SUIT:

15"	17" wheels
303 x 16mm Solid	330 x 26mm Ventilated

### KIT – DIFF TYPE COVERAGE

(Measure Diff flange hole spacing if not known)

Ford Borg Warner

Ford Small bearing 9 inch

Ford Large Bearing 9 inch (*has many clearance issues*)

Ford New style 9 inch

Centura diff

HQ PCD – 330 mm Only (double drilled)

All the above can be a 330 with “other patterns drilled” (double drilled)

15" 303mm

Kit Pricing: Smooth \$1635

330 Rear

Slotted \$1755

Slotted \$2090

Cross Drilled and Slotted \$1850

Cross Drilled and Slotted \$2180

## **HQ-WB, LH-UC (Commodore type) Rear kit 280 by 10**

Smooth \$1575

Slotted \$1695

Cross Drilled and Slotted \$1755

Note: No kit for Banjo or Salisbury Diffs (FE to HK, T, G, HB-LJ)

### **VB to VS Rear HSV type 280 by 20**

These are available in smooth for \$1760 or slotted for \$1840

## **VT – VZ 315 X 18MM REAR KIT**

**CROSS DRILLED AND SLOTTED \$1875**

## **Gemini Rear**

### **GEMINI REAR DISC CONVERSION USING COMMODORE BRAKES - 4 OR 5 STUD**

- 5 STUD REQUIRES AXLES TO BE RE-STUDED OR REPLACED

SMOOTH \$1575

SLOTTED \$1695

DRILLED AND SLOTTED \$1755

Rear Kit Handbrake cables \$350 when purchased with a kit if Available.

## **Caliper Colour Powder Coating: extra \$220 pair**

## **LONG STUDS**

3-INCH-LONG DRAG RACE STUDS AVAILABLE IN 7/16 AND

½ OR 12MM FOR MOST HUBS

EXTRA \$120 PER SET

**Upgrade to Braided hoses for 290/300 Kits**

**ADD \$100 per kit**

**(STANDARD WITH ALL 330 KITS)**

## **HUBS**

## **RESTRICTED SALES**

COMMODORE PATTERN

VB - VP

\$440 pr no bearings \$500 with bearings

GEMINI 5 STUD

\$440 pr no bearings \$500 with bearings

Re-drill hubs and rotors for kit customer only - 5 stud – From \$200



## **HOPPERS STOPPERS 4 AND 6 PISTON CALLIPER'S**

**Add \$2500 to any kit for 4 piston callipers.  
Our 4 piston calliper's use a 28mm thick disc.**

**Add \$3000 to any 330m+ kit  
Our 6 piston calliper's use a 32mm thick disc.**

**Custom logo on calliper – Extra \$400**

**4 and 6 piston calliper's are ADR approved.**

**Can provide proof for your engineer.**

## **BOOSTER KITS**

**HQ-Z/LH-UC 9" Dual Booster Master Conversion Kit** \$870

Call for availability depending on stock levels.

**Landcruiser 78/79 Series 6 or V8 Booster/Master Kits** \$900

**NEW DESIGN 8.5" Booster/Master Kit** \$900

Have Kits for 55 to 68 Chev, XR-XT and Mustang, may fit other cars call for availability.

**Falcon XK /XP with clevis and XB master** \$800

(length with Booster/XB Master 217mm)

## **NEW PBR REMOTE BOOSTERS**

**VH40 \$700**

(230mm Dia x 250mm Long + Pipe)

**VH 44 \$650**

**VACUUM PUMP KIT FOR HIGH PERFORMANCE ENGINES** \$650



# Master Cylinders

JB1419	\$285
XA/XB Ford P6258A	\$265
HQ /HZ Holden P7210	\$250
Chrome billet lid	\$250

VT Fast fill \$300    VT Fitting Kit \$60    Spacer for VB-VS BOOSTER \$60

XB Master - Pipes Exit to guards on RHD, HQ opposite to XB

## Special 014 Undrilled Rotors

HQ/WB DBA 014U

Drilled in "other" pattern, studs fitted and spigot size as per pattern  
 \$300 smooth each / \$360 slotted each / \$400 drilled/slotted each

**WARNING: HQ rotors in HK-HG pattern; tell customer standard HK-HG Wheels will hit HQ calipers**

## Hoppers P76 Rotors (2920)

Smooth \$320each

Slotted \$350each

Drilled & Slotted NLA

P76 Blank Available in **RDA** brand only POA, requires bearing adapter kit.

P76 bearing adapter kit \$260 does both sides – TO SUIT HQ STUBS

New P76 reverse hub style kit \$950 with bearings,  
 Bolts and spacers. Rotors not included.

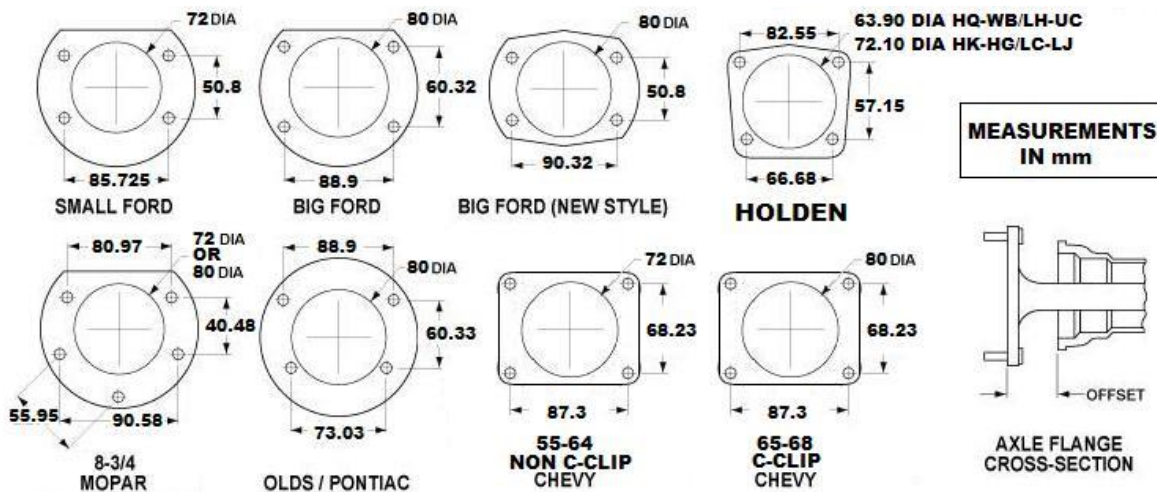

# HQ- WB CALIPERS

HT-HK USE PBR CAST IRON CALIPERS

## HQ-WB

HZ ALLOY GIRLOCK CALIPERS – 1ST CHOICE  
PBR CAST IRON - 2ND  
CAST IRON GIRLOCK - 3RD  
PBR ALLOY - LAST

FOR CHEV 14" WB ALLOY GIRLOCK CALIPER

HZ + WB ALLOY GIRLOCK SEAL KIT: K896S  
PISTONS: DB2749  
PADS: DB1023 GCT  
OR GDB 7503

PBR CAST IRON CALIPER SEAL KIT: K674S  
MAJOR KIT: K1670S (small pins)  
MAJOR KIT: K1775S (large pins, Cal -square cutout)  
PISTONS: DB2140  
PADS: DB6GCT  
OR GDB 7569

PBR ALLOY CALIPER SEAL KIT: K881S (TORANA/TRAILER)  
HX PISTONS: DB2470  
PADS: DB1029GCT DB1028  
OR GDB 7599 GDB7600

GIRLOCK CAST IRON SEAL KIT: K844S  
PISTONS: DB2140  
PADS: DB1004GCT  
OR GDB 7501

SUPPLY RECO CALIPERS / NEW PISTONS AND SEALS

RECO NEW SEALS/PISTONS

HZ/WB GIRLOCK \$750  
HQ CAST IRON \$800

ALL ..... \$150ea

# A , F and X body GM drum stub interchangeability

The following cars use the same basic kits as 67/69 Camaro

## A body (Chev Bolt Pattern)

62/76 Chevy II,  
64-72 Century, Chevelle, Cutlass, El Camino (Not 59/60), 442, F85, Gran Prix, Gran Sport, GSX, GTO, Lemans, Malibu, Monte Carlo, Skylark, Buick Special, Sportswagon, Tempest, Vista Cruiser.

## F Body

Camaro 67/69, Firebird 67/69, Firehawk, SS, Trans Am

## X Body

68 /74 Nova, 71-77 Ventura or II.

# Chrysler drum stub interchangeability

## A Body- Mono Body, same as Aussie Valiant

Valiant, Dodge Dart 63/72, Barracuda 64/69

## B Body 1/2 Chassis front clip

62/64 Phoenix/Fury, 65/72 Belvedere, Coronet,  
73/74 Coronet, GTX, Bevedere, Satellite, Road Runner  
66/69 Dodge Charger

## C Body full chassis

65/68 Dodge Phoenix, Plymouth Fury

## E Body ½ chassis front clip

Cuda, Challenger, Coronet, R/T, Super Bee.  
Note inner bearing change in 1973.

# **Ford stub interchangeability**

**1957 to 1968 Fairlane/Tank/ Galaxie drum stubs are all the same.  
Equivalent year 57/68 Mercury and Edsel are same as Ford**

**52/ 56 Mercury/Lincoln stubs are same as 54/56 Ball Joint USA Ford**

**Australia had Customlines/Mainlines from 55 to 59,  
USA discontinued this model car in 57.**

**54 USA Fords had the ball joint front stub that Australia did not get until 55**

**Mustang 65/66 with K/H 4 spot discs used the drum stub as a base.**

**Mustang 1967 to 69/ USA Falcon/ Ranchero and Cougar disc stubs are same as XW/XY a/b bearings  
70/73 (Large) Mustang and Cougar/Ranchero disc stubs are same as XA/XF e/f bearings**

## **UNUSUAL STUFF -ASK FOR INFO**

**SUNBEAM ALPINE/TIGER  
HILLMAN MINX/VOUGE/RAPIER**

**EARLY 50'S HUDSON STEPDOWN**

**COMMER FORWARD CONTROL VAN.**

**PONTIAC 55/6/7**

**Dodge AT4 \$1800**

**BUICK 57/59 Inter AL130**

**REBEL RAMBLER**

**MORRIS MINOR**

**FORD COURIER / MAZDA B2200**